

Data sheet

Solenoid coil

Types BB, BE, BF, BG, and BN



The coils are specially designed to operate in the aggressive environment of high humidity and temperature fluctuations that you find in most refrigeration systems.

The Clip-on fastening system ensures a faultless installation and makes the coils easy to mount and dismount. A Danfoss Clip-on coil can be mounted without any tools at all, and it is simple to dismount the coil by means of a screwdriver.

The Clip-on coils are available for the entire range of Danfoss solenoid valves for refrigeration, freezing and air conditioning purposes.

Features

- Encapsulated coils with long operating life, even under extreme conditions.
- Standard coils for AC or DC
- Standard coils available with 3-core cable, terminal box or DIN plugs.
- Standard coils from 12 V to 420 V, 50, 60 or 50/60 Hz.
- Standard coils dimensioned for max. opening differential pressure (MOPD) of up to 38 bar.
- Coils can be fitted without the use of tools.

Approvals

- RoHS Directive 2011/65/EU
- Low Voltage Directive (LVD) 2014/35/EU
- EMC Directive 2014/30/EU

Technical data

Data	Solenoid coil type											
	1m 3-core cable	Terminal box				DIN spade and protection cap	DIN spade	1m 3-core cable	Terminal box	DIN spade and protection cap	DIN spade	Terminal box IP67
Enclosure	IP67	IP67	IP67	IP67	IP20	IP00	IP67	IP67	IP20	IP00	IP67	
Pollution degree	4	4	4	4	3	3	4	4	3	3	3	
Conductor area [mm ²]	0.75	0.75 - 1.5	0.75 - 1.5	0.75 - 1.5	0.75 - 1.5	0.75 - 1.5	0.75	0.75 - 1.5	0.75 - 1.5	0.75 - 1.5	0.75 - 1.5	
Cable size [mm]	Ø6.6	Ø6.0 - Ø11	Ø6.0 - Ø11	Ø6.0 - Ø11	Ø6.0 - Ø11	Ø6.0 - Ø11	Ø6.6	Ø6.0 - Ø11	Ø6.0 - Ø11	Ø6.0 - Ø11	Ø6.0 - Ø11	
Rated impulse voltage [kV], if altitude < 4000 m	4	4	4	4	4	4	4	4	4	4	4	
Humidity [R.H.]	0 – 100%	0 – 100%	0 – 100%	0 – 100%	0 – 97% non-condensation condition	0 – 97% non-condensation condition	0 – 100%	0 – 100%	0 – 97% non-condensation condition	0 – 97% non-condensation condition	0 – 100%	
Type of control	1	1	1	1	1	1	1	1	1	1	1	
Safety classification	Class I	Class I	Class I	Class I	Class I	Class I	Class I	Class I	Class I	Class I	Class I	
Max. altitude above sea level [m]	4000	4000	4000	4000	4000	4000	4000	4000	4000	4000	4000	

Note:

For DIN plug, impulse withstand voltage is 3.1 kV for 2000 m < Altitude < 4000 m

! Safety notes for flammable refrigerants (R290, R600, R600A, R32, R1234ze, and R1234yf):

1. The products (only refer to IP65/67 coils) are validated in accordance to ISO 5149, IEC 60335 (ref. IEC/EN 60079-15). Ignition risk is evaluated in accordance to ISO 5149 and IEC 60335 (ref. IEC/EN 60079-15). See safety note below.
2. Please make sure that there is no spark, arc during the application, especially the connection of coils.
3. Follow the instruction to mount the coil correctly and apply the o-ring for sealing, to prevent the moisture penetrate inside the coils.
4. Always install a fuse ahead of the coil to avoid short circuit (fuse size should be around 2 times of rated current, and time lag: medium);
5. The coil used in an area of not more than pollution degree 2.

! Safety notes:

1. The product (only refer to IP65/67 coils) can be applied on systems with R290, R600, R600A, R32, R1234ze, and R1234yf as the working fluid.
2. For countries where safety standards are not an indispensable part of the safety system Danfoss recommend the installer to get a third party approval of the system containing flammable refrigerant.
3. Note, please follow specific selection criteria stated in the datasheet for these particular refrigerants.
4. Note that the product (only refer to IP65/67 coils) has NOT been verified ATEX or IECEx or IEC 60079 series zone 2 compliant. This product is only validated for systems in compliance with ISO5149, IEC 60335 (ref. IEC/EN 60079-15). It is the responsibility of the user to verify such compliance. Improper use can cause explosion, fire, leakage potentially causing death, personal injury, or damage to property.

Approvals

See under the required solenoid valve.

Connection
3-core cable

The external thread in the screwed cable entry suits flexible steel hose or corresponding cable protection (3 x 0.75 mm²).

Terminal box

Leads are connected to terminal screws in the terminal box. The box is fitted with a Pg 13.5 screwed entry for 6 – 14 mm cable.
Max. lead cross section: 2.5 mm².

DIN plugs

The three pins on the coil can be fitted with spade tabs, 6.3 mm wide (to EN175301-803A).
The two current carrying pins can also be fitted with spade tabs, 4.8 mm wide.
Max. lead cross section: 1.5 mm².
Use of the protective cap supplied will prevent inadvertent contact with live parts.

DIN socket

(to EN175301-803A)
Leads are connected in the socket. The socket is fitted with a Pg 11 screwed entry for 6 – 12 mm.

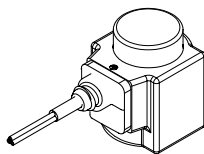
**Ordering
BF solenoid coil with
1m 3-core cable IP67**

Type	Valve type	Tambient [°C]	Supply voltage [V]	Voltage variation	Frequency [Hz]	Power consumption		Code no.
						[W]	[VA]	
BF024AS	EVR 2 – EVR 40 (NC) EVR 6 – EVR 22 (NO) EVRH 10 – EVR 40 EVRC EVRA EVRAT EVRS / EVRST EVM (NC)	-40T80	24	-15%, +10%	50	12	20	018F6257
BF230AS		-40T80	230	-15%, +10%	50	12	22	018F6251
		-40T80	220	-15%, +10%	50	11	20	
BF240AS		-40T80	240	-15%, +10%	50	11	19	018F6252
BF400AS		-40T80	380 / 400	±10%	50	10	21	018F6253
BF024BS		-40T80	24	-15%, +10%	60	14	25	018F6265
BF115CS		-40T80	115	-15%, +10%	60	13	22	018F6260
		-40T80	100	-15%, +10%	50	11	19	
BF220BS		-40T80	220	-15%, +10%	60	14	23	018F6264
BF110CS		-40T50	110	±10%	50	15	29	018F6280
		-40T50	110	±10%	60	13	23	
BF230CS		-40T50	220 – 230	±10%	50	16	31	018F6282
		-40T50	220 - 230	±10%	60	14	24	

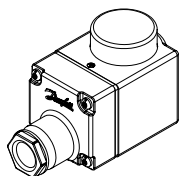
**BE solenoid coil with
terminal box IP67**

Type	Valve type	Tambient [°C]	Supply voltage [V]	Voltage variation	Frequency [Hz]	Power consumption		Code no.
						[W]	[VA]	
BE012AS	EVR 2 – EVR 40 (NC) EVR 6 – EVR 22 (NO) EVRH 10 – EVR 40 EVRC EVRA EVRAT EVRS / EVRST EVM (NC)	-40T80	12	-15%, +10%	50	10	18	018F6706
BE024AS		-40T80	24	-15%, +10%	50	12	21	018F6707
BE042AS		-40T80	42	-15%, +10%	50	10	21	018F6708
BE048AS		-40T80	48	-15%, +10%	50	10	21	018F6709
BE115AS		-40T80	115	-15%, +10%	50	11	19	018F6711
		-40T80	230	-15%, +10%	50	12	22	
BE230AS		-40T80	220	-15%, +10%	50	11	19	018F6701
		-40T80	240	-15%, +10%	50	11	19	
BE240AS		-40T80	240	-15%, +10%	50	11	19	018F6702
BE440CS		-40T80	380 – 400	-15%, +10%	50	13	23	018F6703
		-40T80	440	-15%, +10%	60	14	24	
BE440AS		-40T80	420	-15%, +10%	50	11	21	018F6704
BE024BS		-40T80	24	-15%, +10%	60	14	25	018F6715
BE115CS		-40T80	100	-15%, +10%	50	11	19	018F6710
		-40T80	115	-15%, +10%	60	13	22	
BE220BS		-40T80	220	-15%, +10%	60	13	23	018F6714
BE240CS		-40T80	200	-15%, +10%	50	11	20	018F6713
		-40T80	240	-15%, +10%	60	15	25	
BE110CS		-40T50	110	±10%	50	15	28	018F6730
		-40T50	110	±10%	60	13	22	
BE230CS		-40T50	220 - 230	±10%	50	17	31	018F6732
		-40T50	220 - 230	±10%	60	14	24	

See „Opening differential pressure“ under „Technical data“ for the valve concerned.
When replacing a coil with terminal box, it is sufficient to change the coil unit itself. Therefore, order coil with DIN plugs and protective cap.

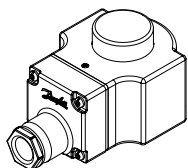
**Ordering
BG solenoid coil with
terminal box IP67**

Type	Valve type	Tambient [°C]	Supply voltage [V]	Voltage variation	Frequency [Hz]	Power consumption		Code no.
						[W]	[VA]	
BG024AS	EVR 3 – EVR 40 EVR EVRAT EVRST EVM (NC/ NO)	-40T80	24	-15%, +10%	50	11	21	018F6807
BG048AS		-40T80	48	-15%, +10%	50	12	26	018F6809
BG110AS		-40T80	110	-15%, +10%	50	13	25	018F6811
BG230AS		-40T80	230	-15%, +10%	50	15	28	018F6801
		-40T80	220	-15%, +10%	50	13	25	
BG240AS		-40T80	240	-15%, +10%	50	13	25	018F6802
BG400AS		-40T80	380 / 400	-15%, +10%	50	12	26	018F6803
BG024BS		-40T80	24	-15%, +10%	60	12	26	018F6815
BG110BS		-40T80	110	-15%, +10%	60	16	29	018F6813
BG220BS		-40T80	220	-15%, +10%	60	16	29	018F6814
BG012DS	EVR 2 – 8 EVR 25 – 40 EVR 3 – EVR 15 (NC) EVR 25 – EVR 40 (NC) EVRAT 10 – EVRAT 15 (NC) EVRST 3 – EVRS/ EVRST 15 EVM (NC/ NO)	-40T50	12	±10%	DC	20	–	018F6856
BG024DS		-40T50	24	±10%	DC	16	–	018F6857
BG048DS		-40T50	48	±10%	DC	20	–	018F6859
BG110DS		-40T50	110	±10%	DC	16	–	018F6860
BG115DS		-40T50	115	±10%	DC	19	–	018F6861
BG220DS		-40T50	220	±10%	DC	20	–	018F6851
BG012DS		EVR 10 – 22 EVR 15 – 20 EVR 20 EVRAT 20 EVRST 20	-40T50	12	±10%	DC	20	–
BG024DS	-40T50		24	±10%	DC	20	–	018F6887
BG048DS	-40T50		48	±10%	DC	20	–	018F6889
BG110DS	-40T50		110	±10%	DC	20	–	018F6890
BG220DS	-40T50		220	±10%	DC	20	–	018F6881

See „Opening differential pressure“ under „Technical data“ for the valve concerned.
When replacing a coil with terminal box, it is sufficient to change the coil unit itself. Therefore, order coil with DIN plugs and protective cap.

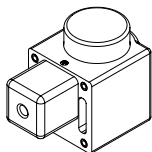
**Ordering
BE solenoid coil with DIN
spade and protection cap
IP20**

Type	Valve type	Tambient [°C]	Supply voltage [V]	Voltage variation	Frequency [Hz]	Power consumption		Code no.
						[W]	[VA]	
BE024AS	EVR 2 – EVR 40 (NC) EVR 6 – EVR 22 (NO) EVRH 10 – EVRH 40 EVRC EVRA EVRAT EVRS/ EVRST EVM (NC)	-40T80	24	-15%, +10%	50	12	21	018F6182
BE230AS		-40T80	230	-15%, +10%	50	12	22	018F6176
BE240AS		-40T80	220	-15%, +10%	50	11	19	018F6177
BE420AS		-40T80	240	-15%, +10%	50	11	19	018F6179
BE115CS		-40T80	420	-15%, +10%	50	10	21	018F6179
		-40T80	100	-15%, +10%	50	11	19	018F6185
BE220BS		-40T80	115	-15%, +10%	60	13	22	018F6185
		-40T80	220	-15%, +10%	50	13	23	018F6189
BE110CS		-40T50	110	±10%	50	15	28	018F6192
		-40T50	110	±10%	60	13	22	018F6192
BE230CS	-40T50	220-230	±10%	50	17	31	018F6193	
	-40T50	220-230	±10%	60	14	24	018F6193	

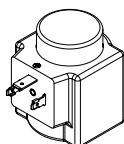
**BB solenoid coil with DIN
spade*)**

Type	Valve type	Tambient [°C]	Supply voltage [V]	Voltage variation	Frequency [Hz]	Power consumption		Code no.
						[W]	[VA]	
BB024AS	EVR 2 – EVR 40 (NC) EVR 6 – EVR 22 (NO) EVRH 10 – EVRH 40 EVRC EVRA EVRAT EVRS/ EVRST EVM (NC)	-40T80	24	-15%, +10%	50	11	19	018F7358
BB115AS		-40T80	115	-15%, +10%	50	11	19	018F7361
BB230AS		-40T80	220 - 230	-15%, +10%	50	11	19	018F7351
BB240AS		-40T80	240	-15%, +10%	50	11	19	018F7352
BB024BS		-40T80	24	-15%, +10%	60	14	23	018F7365
		-40T50	110	±10%	50	15	28	018F7360
BB110CS		-40T50	110	±10%	60	13	22	018F7360
		-40T50	220 - 230	±10%	50	16	31	018F7363
BB230CS		-40T50	220 - 230	±10%	60	13	24	018F7363

See „Opening differential pressure“ under „Technical data“ for the valve concerned.
When replacing a coil with terminal box, it is sufficient to change the coil unit itself. Therefore, order coil with DIN plugs and protective cap.
*) Can only be used with DIN plug.

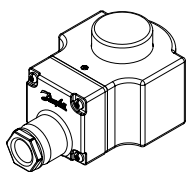
**BN special solenoid coil with
terminal box IP67**

Type	Valve type	Tambient [°C]	Supply voltage [V]	Voltage variation	Frequency [Hz]	Power consumption		Code no. ¹⁾
						[W]	[VA]	
BN024AS	EVR 2 – EVR 40 (NC) EVR 6 – EVR 22 (NO)	-40T50	24	-15%, +10%	50	24	49	018F6904
BN024BS	EVRH 4 – EVRH 40 EVRC/ EVRA/ EVRAT/ EVRS/ EVRST/EVM (NC)	-40T50	24	-15%, +10%	60	22	42	018F6906
BN230AS	EVRH 4 – EVRH 40 EVRC/ EVRA/ EVRAT/ EVRS/ EVRST/EVM (NC)	-40T50	230	-15%, +10%	50	19	43	018F6905

¹⁾ Recommended use for EVRH with high MOPD (38 bar).

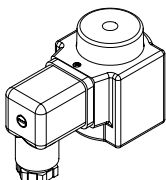
Coil with DIN plug

Terminal box	With built-in light emitting indicator diode for solenoid valves	018Z0089
DIN plug	Enclosure IP65, EN 175301-803A	042N0156

Dimension and weight

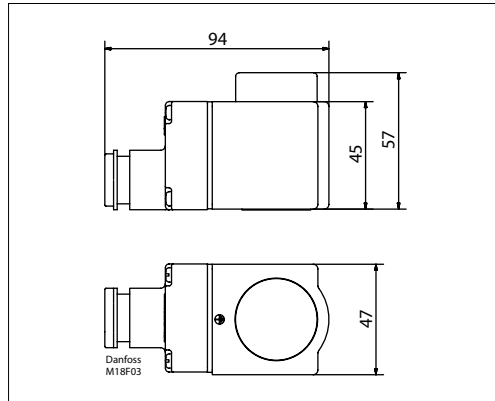

Terminal box 10 W
Weight 0.29 Kg

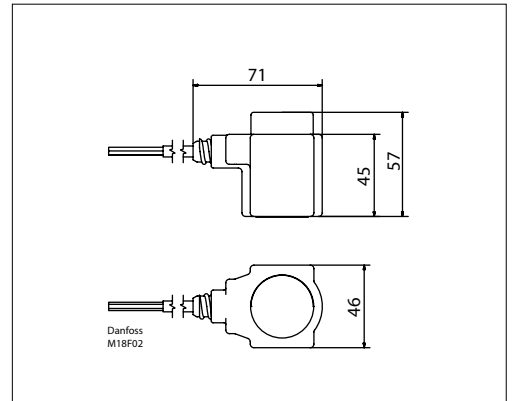

Cable 10 W
Weight 0.29 Kg

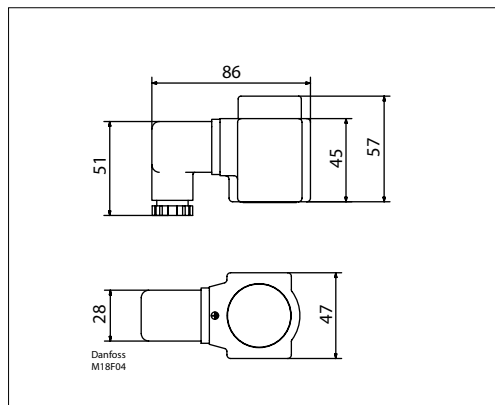

DIN socket 10 W
Weight 0.24 Kg

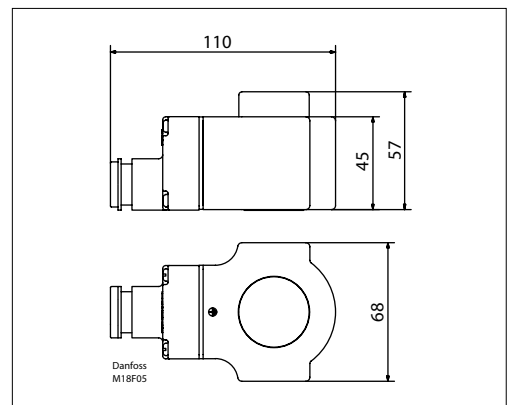

Terminal box 12 - 20 W
Weight 0.55 Kg